

SMART
Correction™
EXTERNAL FIXATOR SYSTEM
Surgical Technique



We **WORK** so they can **PLAY.**™

TABLE OF CONTENTS

Introduction

System Overview 3
Intended Use..... 4

Surgical Technique

Long Bone 4-23
Foot Frame 24-35

System Components

Components by Type 36-41
Case Layouts 42-44



Strong, Lightweight Frame for Enhanced Patient Comfort

The WishBone Medical Smart Correction® System is intended for use in pediatric subgroups (except newborns) and adult patients for the treatment of open and closed fractures, arthrodesis and pseudoarthrosis of long bones, limb lengthening, deformity and angular correction, bony or soft tissue defect correction and malunions.

Smart Correction consists of hexapod fixator elements, surgical instruments, and a copyrighted web-based software application for deformity correction and fracture reduction.

Eren, et al in the Journal of International Orthopaedics (SICOT)¹ reported, "The SC fixator demonstrates higher deformity correction accuracy than an Ilizarov external fixator." Smart Correction offers a wide variety of Wire and pin fixation choices as well as the lowest profile Ring offered at 6mm. The technology creates a strong but lightweight frame for enhanced patient comfort.

The system provides easy assembly, mechanical stability and precise correction in all planes via web-based software www.Click2Correct.com.

USER-FRIENDLY SOFTWARE

Click2Correct™ Preoperative Planning and Templating Software offers an intuitive user interface and improved measuring template library through surgeon collaborations.* The web-based software is available on most common platforms via www.Click2Correct.com.

For more information on the Software, please refer to the Click2Correct Software User Guide (LBL-ST-SCEF-SUG).

**Software is not validated for use with foot frames at this time.*

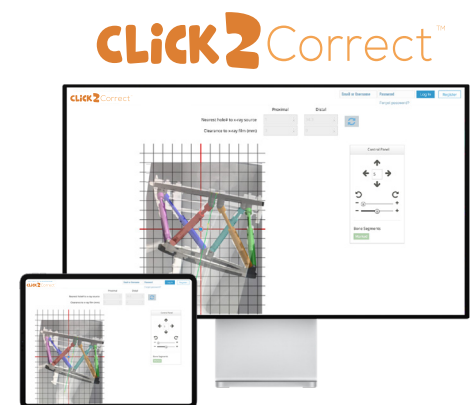

1. Eren, Ilker & Eralp, Levent & Kocaoğlu, Mehmet. (2013). Comparative clinical study on deformity correction accuracy of different external fixators. International orthopaedics. 37. 10.1007/s00264-013-2116-x.

INTENDED USE

INDICATIONS

The Smart Correction® System is indicated for the following:

- Joint contracture resulting in loss of range of motion
- Fractures and disease which generally may result in joint contractures or loss of range of motion
- Fractures requiring distraction
- Open and closed fracture fixation, including fractures of long bones (intracapsular, intertrochanteric, supracondylar, condylar)
- Correction of bony or soft tissue defects
- Correction of bony or soft tissue deformities
- Joint arthrodesis
- Infected fractures or nonunions
- Limb lengthening by epiphyseal or metaphyseal distraction
- Pseudoarthrosis of long bones

CONTRAINDICATIONS

- Patients who are unwilling or incapable of following postoperative care instructions or materials. Express Strut prescription is to be made at the surgeon's discretion. Patients that may attempt unauthorized adjustments and patients with mental, physical, or neurological conditions which may impair the ability to cooperate with the postoperative regimen may not be suitable for use of these devices.
- Not intended for spine applications.

Software is not validated for use with foot frames at this time.

For product information, including indications, contraindications, warnings, precautions and potential adverse effects, as well as Patient Instructions for Use, visit WishBone Medical's Instructions for Use page online: www.WishBoneMedical.com/IFU.

SMART

Correction™

EXTERNAL FIXATOR SYSTEM

SURGICAL TECHNIQUE: LONG BONE

We **WORK** so they can **PLAY.**™



SURGICAL TECHNIQUE: LONG BONE

Ring Selection

Ring diameter needs to allow at least 2cm (two fingers) of distance between the skin and the Ring circumferentially (Fig. 1).

Preparation

With a design that enables efficient, precise calculations with unrestricted Strut placement, Smart Correction allows surgeons to customize the frame to meet each patient's needs.



Fig. 1 - Determine Appropriate Ring Diameter

Proximal Ring Positioning

- 1 During preoperative planning, the proximal Ring should be at least 5mm proximal to the fracture or osteotomy site.

Position the Ring such that the fixation hole marked with #1 is placed as approximately anterior to the proximal segment of bone as possible in the sagittal plane (Fig. 2). The Ring is placed perpendicular (at 90°) to the long axis of the bone. All Rings should be placed such that the numbers are oriented right side up when viewed from the distal aspect (Fig. 2).

Note: Half-rings are not validated for use with software and hence do not contain number markings at this time.

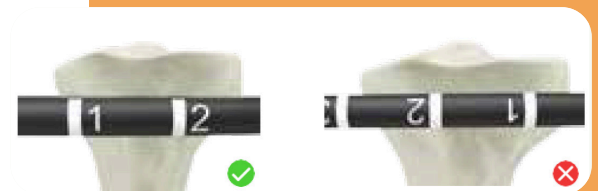

Fig. 2 - Position Proximal Ring

SURGICAL TECHNIQUE: **LONG BONE** (CONT)

Wire Selection

- 2 Wires are offered in standard and olive configurations in two different diameters: 1.6mm and 2.0mm.

Consider patient anatomy prior to selecting Wire size and type. If using an Olive Wire, Wire Stopper Washers are available for use. Insert the Washer onto the sharp end of the Olive Wire prior to Wire insertion.

Warning: Particular care should be taken that Wires and Half Pins do not enter the joints or damage the growth plates in children.

Wire Placement Location

- 3 Consideration of neurovascular structures (safe zones) must be made when inserting Half Pins and Wires.

Caution: Ensure sufficient fixation internal/external to the frame. It is recommended to insert a minimum of three points of fixation per circular Ring and a minimum of four points of fixation per Foot Ring.

Wire Insertion

- 4 Insert the Wire under power perpendicular to the long axis of the bone (Fig. 3). Wait until the Wire is in contact with the bone before drilling. As soon as the tip of the Wire penetrates the far cortex, stop the drill.

Once the Wire exits the bone, drill or tap the Wire through the remaining soft tissue. Be careful of soft tissues when advancing the Wire. Once the Wire is placed, the sharp tip should be cut off to prevent injury while ensuring that a sufficient length remains for tensioning (Fig. 4).



Fig. 3 - Insert Wire



Fig. 4 - Trim Excess Wire

SURGICAL TECHNIQUE: LONG BONE (CONT)

Proximal Ring Placement

- 5 Position the proximal Ring such that the fixation hole marked with #1 is placed anteriorly. Select the location for placement of the first Wire Connector.

Wire Connection

- 6 Using the Standard Wire Clamp (Fig. 5) or Side Load Wire Clamp (Fig. 6), connect the Wire to the Ring.

Note: Both inner and outer ring holes can be used for Wires and Half Pins. The selected Wire Clamp is dependent on the position of the Wire in relation to the Ring and the Clamp that yields the least amount of Wire deformation. For instances where Clamps are placed on Rings before connecting Wires, the side slot of the Side Load Wire Clamp can be used to connect Wires before tightening.

The Side Load Wire Clamp may be used with or without a Washer both on the face of the Ring or with the Advanced Clamp Post to connect Wires in locations off the face of the Ring. Standard Wire Clamps are also compatible with the Advanced Clamp Post, but must be used with a Washer on the face of the Ring or with the Advanced Clamp Post. When using the Side Load Wire Clamp or Standard Wire Clamp with the Advanced Clamp Post, place the Clamp through the slot at any position along the slot length to achieve desired offset.

Tightening Wire Clamps

- 7 While using the end of a 10mm Hex Bolt Wrench to maintain position of the Clamp, use another 10mm wrench to tighten the Nut (Fig. 7). Fully tighten the Nut opposite of where the Tensioner will be applied.

Note: If Side Load Wire Clamps are used, a 13mm Hex Bolt Wrench can be used to maintain the position of the Clamp.



Fig. 5 - Assemble Wire to Standard Wire Clamp

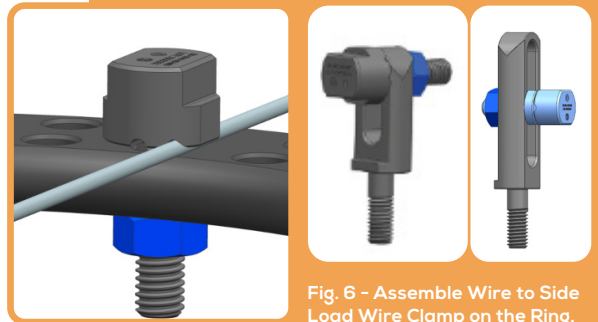

Fig. 6 - Assemble Wire to Side Load Wire Clamp on the Ring, or assemble Wire to Standard Wire Clamp or Side Load Wire Clamp on the Advanced Clamp Post



Fig. 7 - Fully Tighten Nut

SURGICAL TECHNIQUE: LONG BONE (CONT)

Tensioning

- 8 Select desired Wire Tension Head (see table below)

Clamp Compatibility with Tensioner Heads	
Standard Wire Clamp	Fork Tensioner Head Tensioner Head
Side Load Wire Clamp through Thru-Hole	Slotted Tensioner Head Tensioner Head
Side Load Wire Clamp through Side Slot	No Tensioner Head

Attach Wire Tensioner Head to the tensioner body by pressing it into the boss (Fig. 8). Position tensioner over the Wire from the tensioning side of the Ring. Ensure tensioner head is in contact with the Clamp, Advanced Clamp Post, or Ring before tensioning (Fig. 9). The Wire Tensioner contains markings to indicate the amount of tension from 0-125kg (Fig. 10). Wires are recommended to be tensioned between 70-125kg.

Caution: If using an Olive Wire, consider the intended use of the Wire within the correction and if a Wire Stopper Washer was used prior to tensioning. Etched lines are present on the Wire to indicate which side of the bone the olive is on.

Warning: Do not use Tensioner Head with Wire Clamp Bolts that do not use Washer component.

Caution: The thru-hole and side-load feature of the Side Load Wire Clamp should not be used at the same time.

Note: Take care to keep Wire from bending during tensioning. If needed, the tensioner can be used without a Wire Tensioner Head.



Fig. 8 - Assemble Tensioning Device

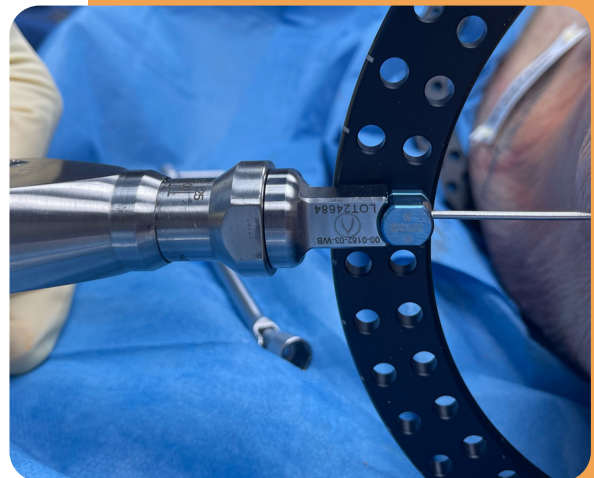

Fig. 9 - Position Tensioner



Fig. 10 - Tension Wires

SURGICAL TECHNIQUE: LONG BONE (CONT)

Tighten Wire Bolt and Nut

- 9 Tighten the Nut to secure the Wire Clamp on the tensioned side of the Ring (Fig. 11).



Fig. 11 - Fully Tighten Nut

Wire Trimming

- 10 Using the Wire Cutter/Plier, cut the end of the Wire leaving enough length to allow for additional tensioning on at least one side if needed (Fig. 12).

Wire covers are available for patient comfort.



Fig. 12 - Trim Excess Wire

Half Pin Insertion

- 11A Select appropriate size and type of Half Pin. Half Pins are offered in self-drilling and self-tapping configurations in 4.5mm, 5.0mm, and 6.0mm thread diameters and 20mm, 30mm, 40mm, and 50mm thread lengths. HA Half Pins are offered with a 6.0mm thread diameter in thread lengths between 30mm and 50mm.

Consider patient anatomy prior to selecting Half Pin size and type. Washers (Standard and Locking) are available for use at connection sites.

Warning: Two Locking Washers should not be used at the same interface. However, a Locking Washer and Standard Washer or two Standard Washers may be used together.

Half Pins can be assembled to the Frame by using the Advanced Pin Clamps, Standard Pin Clamps, Advanced Clamp Posts, and Cubes.

Method 1 - Advanced Pin Clamp Assembly

Advanced Pin Clamps can be attached to inner or outer Ring holes using either standard or Long Nuts. However, most stable fixation is achieved with Clamp placement oriented to the inside of the Ring (Fig. 13).

To achieve optimal fixation of bone fragments, pin angle should be no greater than 30° relative to the Ring.

Caution: Advanced Pin Clamps should only be used with Half Pins.

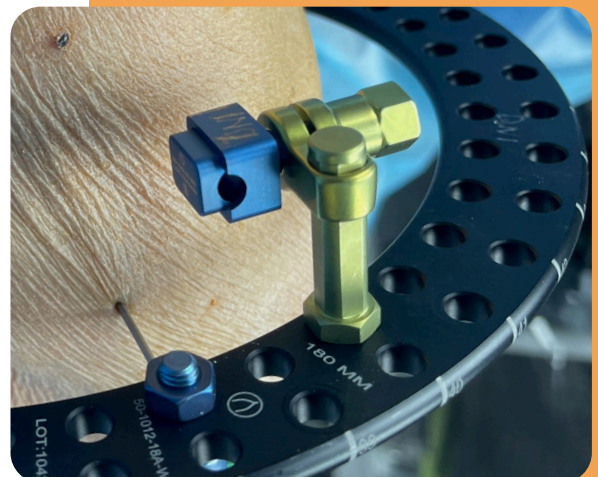

Fig. 13 - Assemble Advanced Pin Clamp to Ring

SURGICAL TECHNIQUE: LONG BONE (CONT)

Half Pin Insertion (Continued)

Method 2 - Standard Pin Clamp Assembly

Standard Pin Clamps can be attached to inner or outer Ring holes using either Standard or Long Nuts (Fig. 14).

Method 3 - Standard Pin Clamp with Advanced Clamp Post

Standard Pin Clamps can be used in conjunction with an Advanced Clamp Post to achieve offset from the face of the Ring. Place Pin Clamp through the slot at any position along the slot length to achieve desired offset (Fig 15).

To achieve optimal fixation of bone fragments, pin angle should be no greater than 30° relative to the Ring.

Method 4 - Cube Assembly

Cubes can be assembled to the Ring via gold bolts (Fig. 16A). If Washers are used, longer bolt length may be required.

Insert Pin Sleeve through the Cube, ensuring the line on the Pin Sleeve is aligned to the threaded holes on the Cube (Fig. 16B).

Once Half Pin is inserted into the bone through the Cube, insert the Set Screw through threaded holes of the Cube and tighten using the T-Allen Wrench to lock the Half Pin in place (Fig. 16B).

Caution: Washers should only be used between the bottom side of the Ring and the Nut that is securing the Cube. No more than two Washers should be used at a single connection site.

Note: If Washers are used with the Cube, the 16mm Connection Bolt should be used. However, the Cube hole closest to the Ring should not be used for Half Pin connection.

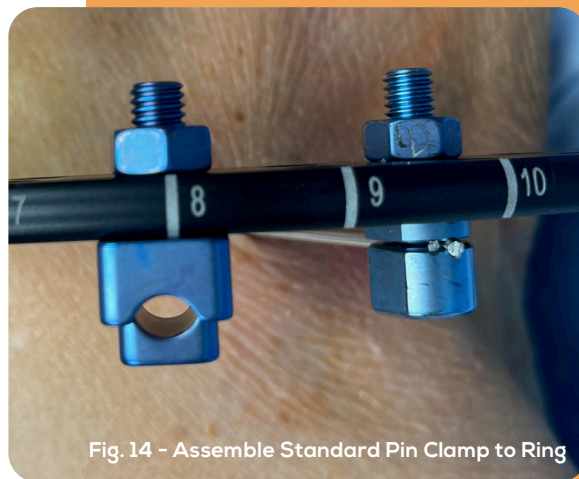

Fig. 14 - Assemble Standard Pin Clamp to Ring

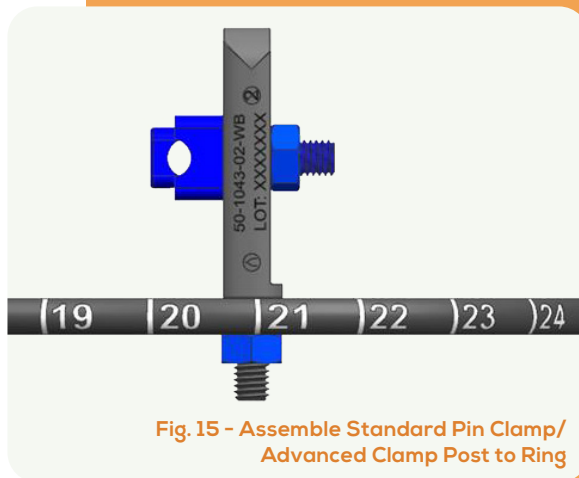

Fig. 15 - Assemble Standard Pin Clamp/ Advanced Clamp Post to Ring



Fig. 16 - Assemble Cube to Ring



Fig. 16B - Assemble Cube to Ring

SURGICAL TECHNIQUE: LONG BONE (CONT)

Predrilling for Half Pins (Optional)

11B Drill bits are available for predrilling for Half Pins. Drill Sleeve Guides and Trocars are available to aid with drilling and Half Pin insertion.

Thread the Drill Sleeve Guide into the Drill Sleeve Handle. From there, it can be used with Half Pins, drill bits, and trocars. There are long and short trocars for use with the long and short Drill Sleeve Guides (Fig. 17A).

- **Half Pins (120mm-150mm):**
Use Short Drill Sleeve Guide/Trocar
- **Drill bits & Half Pins (180mm & up):**
Use Long Drill Sleeve Guide/Trocar
- To aid in the alignment of the drill bit, Half Pin, and Connector placement, the trocar can be placed directly through the Connector to mark location for drilling (Fig. 17B). Following this, the Connector can be moved out of the way so that the drill bit or Half Pin may be used through Drill Sleeve Guide. When drilling or inserting Half Pins, the component should be inserted until bicortical bone purchase is achieved.

A Depth Gauge is available to aid in the selection of the appropriate Half Pin.

After predrilling, the Depth Gauge should be used such that the Depth Gauge body comes into contact with the bone and the Depth Gauge Wire can be placed through the predrilled hole. The hook at the end of the Wire can grab onto the far cortex. The measurement indicated by the Depth Gauge reflects the appropriate Half Pin thread length (Fig. 18).

In the occurrence that the measurement does not correspond to a Half Pin thread length, the next largest Half Pin thread length should be chosen to ensure full thread engagement and that bicortical bone purchase is achieved.

Use power or a T-Handle to insert Half Pin. Tighten Clamp to Half Pin. A single-use AO Quick Release Adaptor is available to connect to the square chuck on the HA Half Pins for insertion.

Note: Predrilling is required for self tapping Half Pins. Predrilling for self-drilling Half Pins is recommended for hard, dense cortical bone.

Note: 3.2mm Drill Bit must be used for 4.5 & 5.0mm Half Pins; 4.8mm Drill Bit must be used for 6.0mm Half Pins. Fully coated HA Half Pins require pre-drilling with the provided 4.0mm Drill Bit (Long or Short). Pre-drilling is optional for HA Coated Half Pins with un-coated tips.

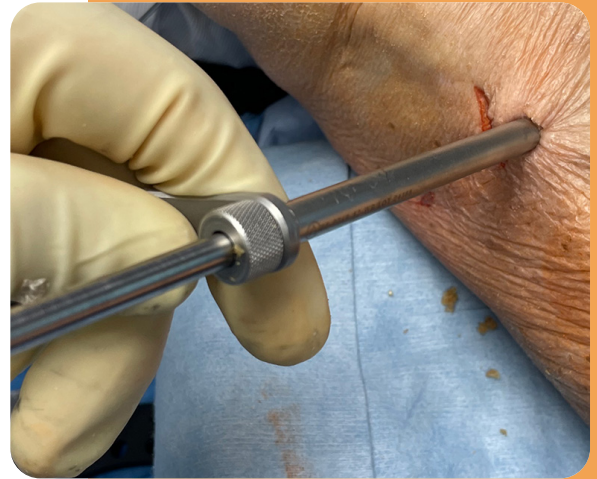

Fig. 17A - Insert Trocar/Half Pin into Drill Guide Assembly

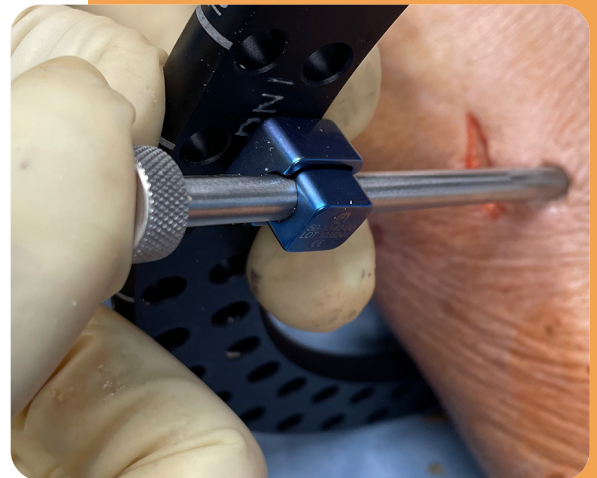

Fig. 17B - Assemble Trocar to Connector



Fig. 18 - Read Depth Gauge Marking

2nd Half Pin

- 12 Following the same method described in **Step 11**, insert a second Half Pin divergent to the first Half Pin (Fig. 19).

Standard and Advanced Clamps can be attached to the Ring using Standard or Long Nuts.

Cubes may also be used to attach additional Half Pins to Rings. Attach Cube to the Ring using a Connection Bolt. Insert Pin Sleeve into the hole where the Half Pin is to be inserted. Insert the Half Pin into the bone. Once desired position is achieved, secure the Half Pin to the Cube using the 6mm Set Screw and a T-Allen Wrench.

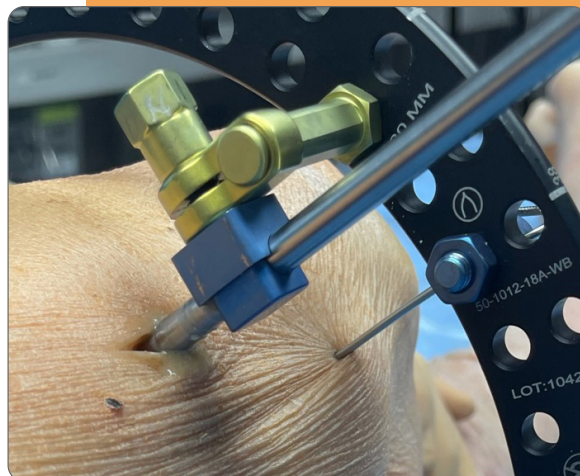

Fig. 19 - Insert 2nd Half Pin

Remaining Half Pins(s) / Wire(s)

- 13 Insert additional Half Pins or Wires being careful to avoid planned location of Struts.

Caution: Clamps and Cubes may not fit in directly adjacent Ring holes.

Note: Ensure that the groove on the Washer on the Standard Wire Clamp is aligned with the Wire.

Trim excess length of Wires and/or Half Pins using the Wire Cutter/Plier or Rod Cutter (Fig. 20).

Half Pin and Wire covers are available for patient comfort.

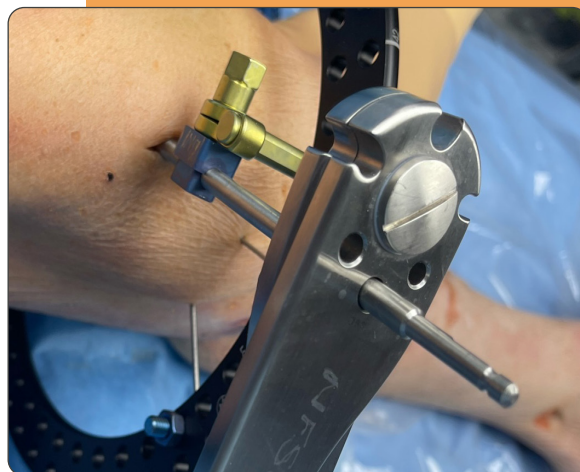

Fig. 20 - Trim Excess Wires/Pins

Place the Distal Ring

- 14 Ring diameter needs to allow at least 2cm (two fingers) of distance between the skin and the Ring circumferentially.

Position the distal Ring such that the fixation hole marked with #1 is placed anteriorly (Fig. 21).

Note: Half-rings are not validated for use with software and hence do not contain number markings at this time.

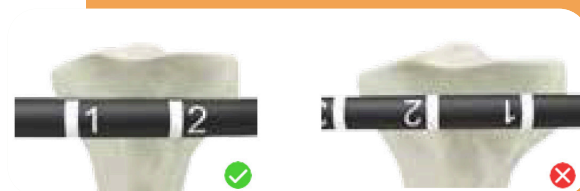

Fig. 21 - Position Distal Ring

SURGICAL TECHNIQUE: **LONG BONE** (CONT)

Insert Wire(s)

- 15 Insert the Wire as outlined in **Steps 4-10**.

Align the Distal Ring

- 16 The distal Ring should be aligned parallel to the proximal Ring.

Perform Half Pin Insertion

- 17 Insert the Half Pin(s) as outlined in **Steps 11-13**.

Double Check Tightness of All Connectors

- 18 All connections must be fully tightened using the 10mm Hex Bolt Wrench prior to Strut placement (Fig. 22).

Caution: Torque Limiting Ratchet Wrench is intended to be used to tighten Shoulder Bolts to Struts. Use with other Connector elements may not provide sufficient torque.



Fig. 22 - Tighten All Connectors

Select the Appropriate Strut

- 19 Both Express Struts (for rapid adjustment) and Standard Struts are available.

Warning: Express Strut use should be determined by the surgeon. Patients that may attempt unauthorized adjustments, and patients with mental, physical, or neurological conditions which may impair the ability to cooperate with the postoperative regimen, may not be suitable for use of these devices.

Note: Size selection should be made with consideration of Strut exchange (Fig. 23).

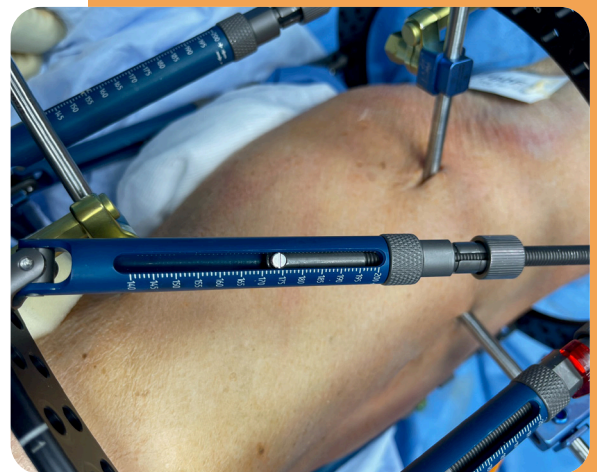

Fig. 23 - Select Strut Type and Size

Fix Struts to Ring

20 The Struts must be installed and fixed to the outer Ring holes for software compatibility, in a rough triangular geometric configuration. The Struts should be placed in pairs approximately equidistant around the circumference of the Ring and secured to the Ring using Shoulder Bolts (Fig. 24).

Tighten Shoulder Bolts using two 10mm wrenches (Fig. 25).

Note: It is recommended to tighten the Shoulder Bolts to 8Nm of torque. An 8Nm Torque Limiting Ratchet Wrench is available to achieve this.

The modular nature of Smart Correction allows surgeons to choose the final position of the Struts, even allowing the Struts in a particular pair to be separated by a number of holes for easy access to potential wound sites or skin flaps.

Note: Different diameter Rings can be used in the same frame as needed. Full Rings may also be combined with 2/3 Rings or Foot Rings.

Note: A surgeon must use the recommended six Struts if utilizing the Smart Correction Software.

Warning: Washers cannot be used at Strut attachment sites.



Fig. 24 - Position and Secure Struts



Fig. 25 - Tighten Shoulder Bolts

SURGICAL TECHNIQUE: LONG BONE (CONT)

Strut Positioning

21 Ideal Strut positions are shown in the tables below.

Note: Use Shoulder Bolts, 6mm (silver) on Full Rings.
Use Shoulder Bolts, 8mm (purple) on Partial Rings.

Proximal Ring Size	S1 & S2	S3 & S4	S5 & S6	Acceptable Tolerance
70mm	1 & 2	7 & 8	14 & 15	± 1 hole
80mm	1 & 2	8 & 9	15 & 16	± 1 hole
90mm	1 & 2	9 & 10	17 & 18	± 1 hole
105mm	1 & 2	10 & 11	19 & 20	± 2 holes
120mm	1 & 2	11 & 12	21 & 22	± 2 holes
135mm	1 & 2	12 & 13	23 & 24	± 2 holes
150mm	1 & 2	13 & 14	25 & 26	± 2 holes
165mm	1 & 2	14 & 15	27 & 28	± 3 holes
180mm	1 & 2	15 & 16	29 & 30	± 3 holes
195mm	1 & 2	16 & 17	31 & 32	± 4 holes
210mm	1 & 2	17 & 18	33 & 34	± 4 holes
225mm	1 & 2	18 & 19	35 & 36	± 4 holes
240mm	1 & 2	19 & 20	38 & 39	± 4 holes

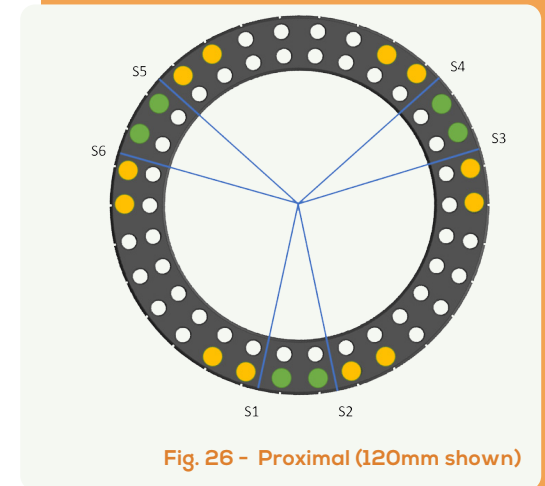

Distal Ring Size	S2 & S3	S4 & S5	S6 & S1	Acceptable Tolerance
70mm	4 & 5	10 & 11	17 & 18	± 1 hole
80mm	5 & 6	12 & 13	19 & 20	± 1 hole
90mm	5 & 6	13 & 14	21 & 22	± 1 hole
105mm	25 & 6	7 & 15	16 & 24	± 2 holes
120mm	6 & 7	16 & 17	26 & 27	± 2 holes
135mm	6 & 7	17 & 18	28 & 29	± 2 holes
150mm	7 & 8	19 & 20	31 & 32	± 2 holes
165mm	7 & 8	20 & 21	32 & 33	± 3 holes
180mm	8 & 9	22 & 23	36 & 37	± 3 holes
195mm	9 & 10	24 & 25	39 & 40	± 4 holes
210mm	9 & 10	25 & 26	41 & 42	± 4 holes
225mm	10 & 11	27 & 28	44 & 45	± 4 holes
240mm	8 & 9	25 & 26	43 & 44	± 4 holes

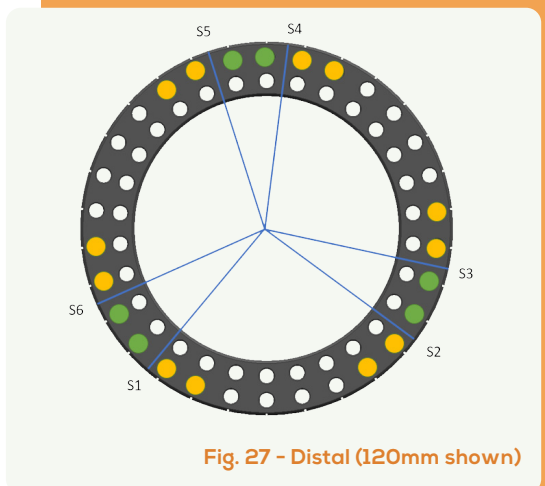

SURGICAL TECHNIQUE: **LONG BONE** (CONT)

Posterior Open

Proximal 2/3 Ring Size	S1 & S2	S3 & S4	S5 & S6
70mm	9 & 10	14 & 15	4 & 5
80mm	10 & 11	16 & 17	5 & 6
90mm	11 & 12	18 & 19	5 & 6
105mm	13 & 14	21 & 22	6 & 7
120mm	15 & 16	24 & 25	7 & 8
135mm	16 & 17	26 & 27	7 & 8
150mm	19 & 20	29 & 30	8 & 9
165mm	20 & 21	31 & 32	8 & 9
180mm	21 & 22	34 & 35	9 & 10
195mm	23 & 24	37 & 38	10 & 11
210mm	24 & 25	39 & 40	10 & 11
225mm	27 & 28	42 & 43	11 & 12
240mm	27 & 28	44 & 45	11 & 12

Anterior Open

Distal 2/3 Ring Size	S2 & S3	S4 & S5	S6 & S1
70mm	4 & 5	9 & 10	14 & 15
80mm	5 & 6	10 & 11	16 & 17
90mm	5 & 6	11 & 12	18 & 19
105mm	6 & 7	13 & 14	21 & 22
120mm	7 & 8	15 & 16	24 & 25
135mm	7 & 8	16 & 17	26 & 27
150mm	8 & 9	19 & 20	29 & 30
165mm	8 & 9	20 & 21	31 & 32
180mm	9 & 10	21 & 22	34 & 35
195mm	10 & 11	23 & 24	37 & 38
210mm	10 & 11	24 & 25	39 & 40
225mm	11 & 12	27 & 28	42 & 43
240mm	11 & 12	27 & 28	44 & 45

Foot Ring Size	S1 & S2	S3 & S4	S5 & S6
S - 105mm	9 & 20	19 & 14	13 & 8
M - 120mm	10 & 23	22 & 17	16 & 9
L - 135mm	11 & 26	25 & 19	18 & 10

SURGICAL TECHNIQUE: **LONG BONE** (CONT)

Align Strut

- 22 Align the Strut with the intended Ring hole. Position the Strut so that length indicator is visible (Fig. 28).

Thread Appropriate Bolts

- 23 Thread the appropriate size Shoulder Bolt into the Strut through the outer hole in the Ring (Fig. 29).
 - 6mm Shoulder Bolts (silver) are to be used with Full Rings (6mm thickness)
 - 8mm Shoulder Bolts (purple) are to be used with 1/3, 2/3 and Foot Rings (8mm thickness)

Adjust Strut to Distal Ring

- 24 Repeat **Steps 19-23** for each Strut.

Use Wrenches to Tighten Strut

- 25 Use two 10mm wrenches to tighten the Shoulder Bolts (Fig. 30).

Note: It is recommended to tighten the Shoulder Bolts to 8Nm of torque. An 8Nm Torque Limiting Ratchet Wrench is available for Shoulder Bolt tightening.



Fig. 28 - Align and Position Strut

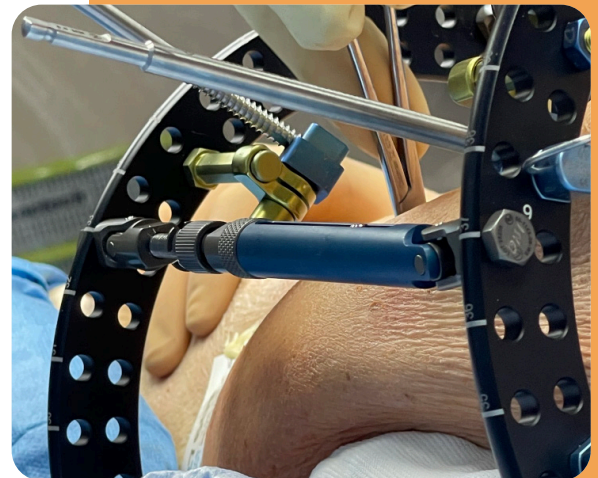

Fig. 29 - Assemble Shoulder Bolts to Struts



Fig. 30 - Tighten Shoulder Bolts

Tighten Locking Collar

- 26 If using an Express Strut, tighten Strut Locking Collar counterclockwise until Strut height is fixed in place such that no gross adjustments can be made (Fig. 31).

Note: The Express Strut Locking Collar is designated by straight knurls.

Warning: Express Strut use is to be made at the surgeon's discretion. Patients that may attempt unauthorized adjustments and patients with mental, physical, or neurological conditions which may impair the ability to cooperate with the postoperative regimen may not be suitable for use of these devices.

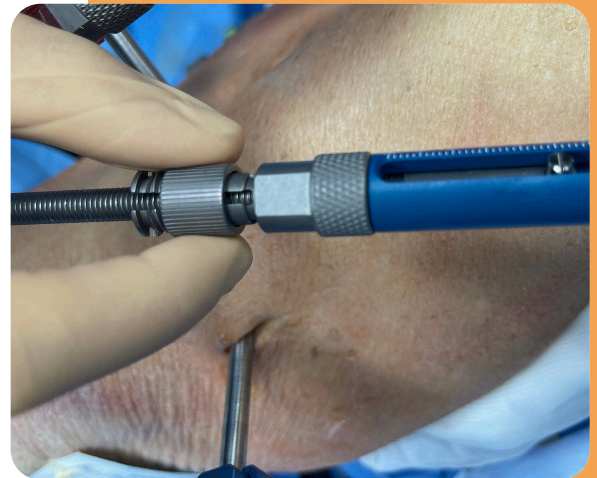

Fig. 31 - Tighten Strut Locking Collar

Re-Tighten Each Bolt and Nut

- 27 All Nuts and bolts should be fully tightened with the 10mm Hex Bolt Wrench. The 13mm Hex Bolt Wrench is available for counter-torque on Cubes and Pin Clamps (Fig. 32).

8Nm Torque Limiting Ratchet Wrench is available for final tightening of Shoulder Bolts.

Caution: Torque Limiting Ratchet Wrench is intended to be used to tighten Shoulder Bolts to Struts. Use with other Connector elements may not provide sufficient torque.



Fig. 32 - Final Tightening of Bolts and Nuts

SURGICAL TECHNIQUE: **LONG BONE** (CONT)

Attach Strut ID Clips

- 28 Ensure that Strut ID Clips are attached to the correct Struts in order (the most anterior Strut as 1). To prevent unintentional disassembly, Standard Struts and XXS Express Struts must have ID clips attached at the top of the Strut (Fig. 33A).

Strut length and position must be recorded and entered accurately into Click2Correct Software to ensure that desired prescription for correction schedule can be calculated and obtained.

Verify that the colors/numbers and orientation of the ID clips are correct prior to using Smart Correction software.

Strut ID clip numbers should be in ascending order in the same orientation as proximal Ring hole numbers (Fig. 33B).



Fig. 33A - Assemble Strut ID Clips



Fig. 33B - Verify Strut ID Clip Orientation

SURGICAL TECHNIQUE: **LONG BONE** (CONT)

Consider Mounting a 2nd Level of Fixation to Increase Stability

- 29 A Full Ring can be built above a previously affixed Ring using a 2/3 and 1/3 Ring of the same size with the 1/3-2/3 Ring Connector, 20mm (green) Connection Bolts (x2) and Nuts (x2) (Fig. 34a) or two 1/2 Rings of the same size with 20mm (green) Connection Bolts (x2) and Nuts (x2) (Fig. 34b).

Note: Use GREEN bolts (20mm Long) for connecting any two partial rings (2/3, 1/3, 1/2)

Partial Rings (2/3, 1/2, 1/3) may be attached to the frame using Struts or Threaded Rods in approximate equidistant position (Fig. 35).

Warning: Single hole at the two ends of each half ring is to be used only for connecting to another half ring and not for other frame elements.

Nuts are available to be placed on either side of the Ring-Threaded Rod attachment site.

Dual Rod Connectors (Optional)

If desired Threaded Rod length is unavailable, Dual Rod Connectors may be used to connect two Threaded Rods together to create an overall length up to 300mm.

The Threaded Rods should be fully threaded into the Connector such that the ends of the Threaded Rods are touching at the approximate center of the Dual Rod Connector. Nuts are available to be placed on either side of the Dual Rod Connector to assist with locking in place the position of the Dual Rod Connector.



Fig. 34a - Assemble Second Level of Frame

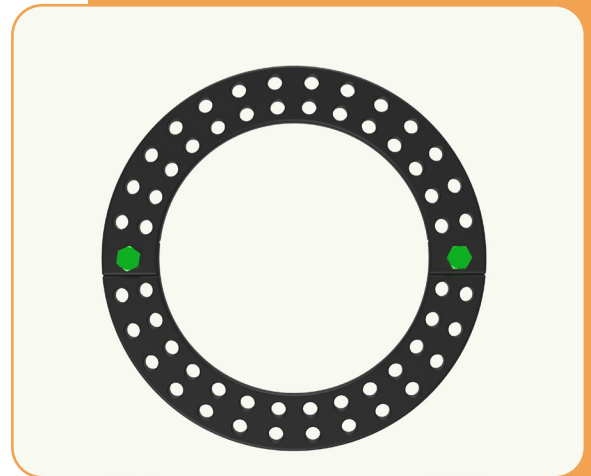

Fig. 34b - Assemble Second Level of Frame



Fig. 35 - Assemble the Second Level of Frame with Threaded Rods

SURGICAL TECHNIQUE: **LONG BONE** (CONT)

Patient Safety & Comfort

Pin and Wire covers are available to place at the end of cut Half Pin and Wires.

Silverlon Lifesaver® Ag pin site dressing, Sponges, and Sponge Clips are available for use at anchorage insertion sites to aid with pin site maintenance (Fig. 36). Silverlon Lifesaver® Ag pin site dressing and/or Sponges can be placed on the insertion site with Sponge Clips available to attach to the anchorage element to hold the Sponge in place. Silverlon Lifesaver® Ag pin site dressings are available in 1.5mm diameter for use with wires and a 4.0mm diameter for use with Half Pins. Activate the Silverlon Lifesaver® Ag pin site dressings by wetting them with sterile water, distilled water, or normal saline. Place the silver side of the dressing in direct contact with the skin.



Fig. 36 - Attach Sponges (Left) and Silverlon Lifesaver Ag pin site dressings (right) with sponge clips

SURGICAL TECHNIQUE: X-RAY IMAGING

X-Ray Positioning

Position the X-ray source over the center of the frame between the two Rings. It is important that the entire frame can be seen on the X-ray.

650mm-1500mm distance (A)

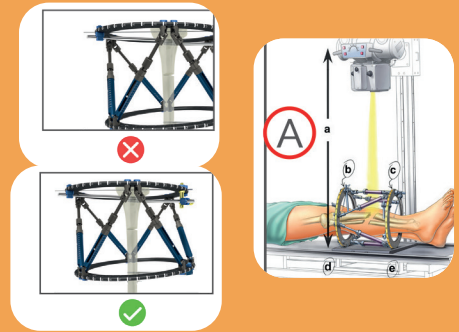

X-Ray Positioning

- 1 Record the number that appears closest to the X-ray source on both the proximal and distal Ring at the time the X-ray is taken (B & C).
- 2 Record the distance between the Rings and X-ray cassette (D & E).

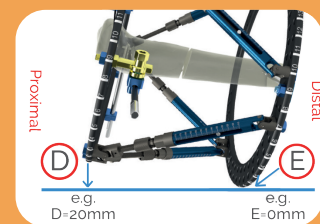

Lateral X-Ray Measurements

- 3 Record the number that appears closest to the X-ray source on both the proximal and distal Ring at the time the X-ray is taken (F & G).
- 4 Record the distance between the Rings and X-ray cassette (H & I).

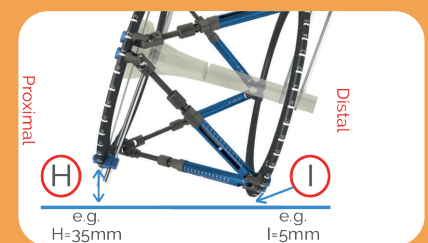

The Smart Correction® Frame Information Form (LIT-FIF-SCEF) is available for frame configuration and X-ray measurement documentation. Access the document online at www.WishBoneMedical.com/product/SC.

SMART

Correction™
EXTERNAL FIXATOR SYSTEM

Surgical Technique: Foot Frame

SURGICAL TECHNIQUE: FOOT FRAME

Ring Selection

Ring diameter needs to allow at least 2cm (two fingers) of distance between the skin and the Ring circumferentially (Fig. 1).

*Software is not validated for use with foot frames at this time.

Foot rings are available in two different lengths for each diameter (standard and short).



Fig. 1 - Determine Appropriate Ring Diameter

Proximal Ring

- 1 Select the appropriate proximal Ring and slide over the affected limb (Fig. 2).

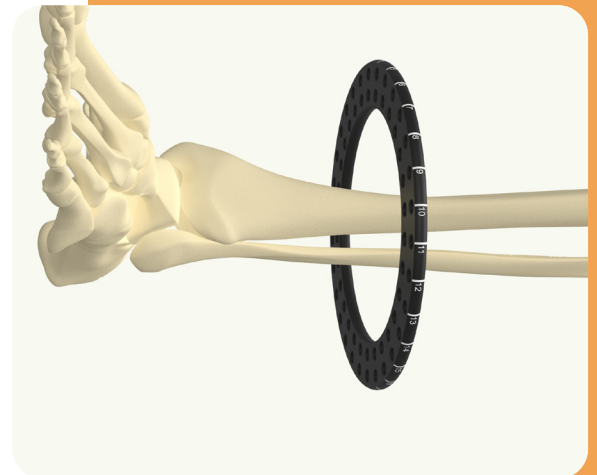

Fig. 2 - Position the Proximal Ring

Select Foot Ring

- 2 Select the appropriate size of Foot Ring, ensuring to have at least 2cm between the skin and Ring (Fig. 3).

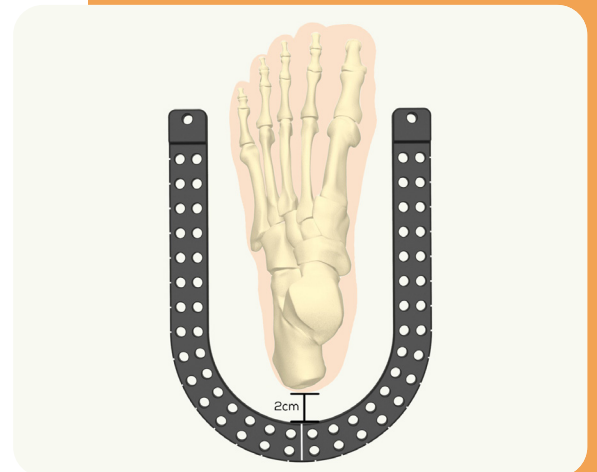

Fig. 3 - Determine Appropriate Foot Ring

SURGICAL TECHNIQUE: FOOT FRAME (CONT)

Position Foot Ring

- 3 Position Ring so that the foot is centered and parallel (Fig. 4a).

Alignment line marking on the foot rings can be used to aid in the alignment (Fig. 4b).



Fig. 4a - Position Foot Ring

Wire Selection and Placement

- 4 Wires are offered in standard and olive configurations in two different diameters: 1.6mm and 2.0mm. Consider patient anatomy prior to selecting Wire size.

Note: If using an Olive Wire, Wire Stopper Washers are available for use. Insert the washer onto the sharp end of the Olive Wire prior to Wire insertion.

Caution: Ensure sufficient fixation internal/external to the frame. It is recommended to insert a minimum of four points of fixation per Foot Ring.

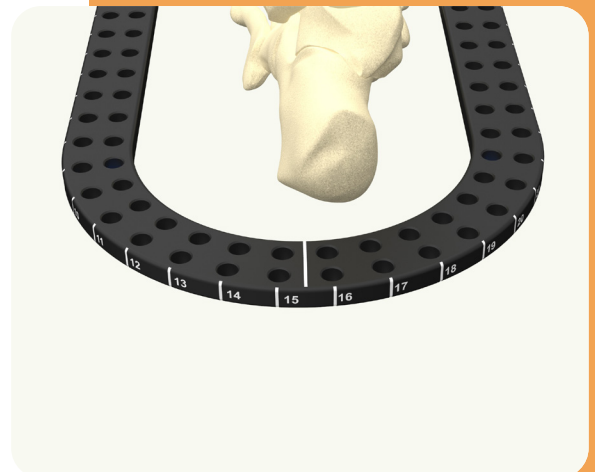

Fig. 4b - Alignment line markings

Wire Insertion

- 5 Insert Wire under power through the posterior calcaneus in line with the Foot Ring (Fig. 5).

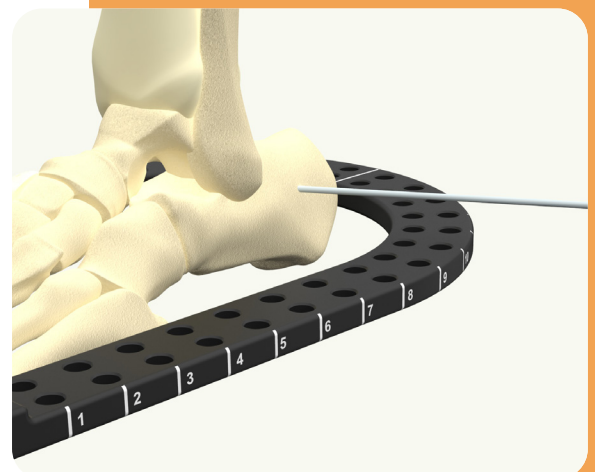

Fig. 5 - Insert Wire

SURGICAL TECHNIQUE: FOOT FRAME (CONT)

Wire Connection

- 6 Connect the Wire to the Foot Ring using the Standard or Side Load Wire Clamps (with or without Advanced Clamp Posts) (Fig. 6).

The Side Load Wire Clamp may be used with or without a Washer both on the face of the Ring or with the Advanced Clamp Post to connect Wires in locations off the face of the Ring. Standard Wire Clamps are also compatible with the Advanced Clamp Post, but must be used with a Washer on the face of the Ring or with the Advanced Clamp Post. When using the Side Load Wire Clamp or Standard Wire Clamp with the Advanced Clamp Post, place the Clamp through the slot at any position along the slot length to achieve desired offset.

Note: Ensure Clamps are not at the end of the Foot Ring such that it can be closed off, per Step 7 below.

Warning: Single hole at the two ends of the foot ring are to be used only for closing off the foot ring and not for other frame elements.

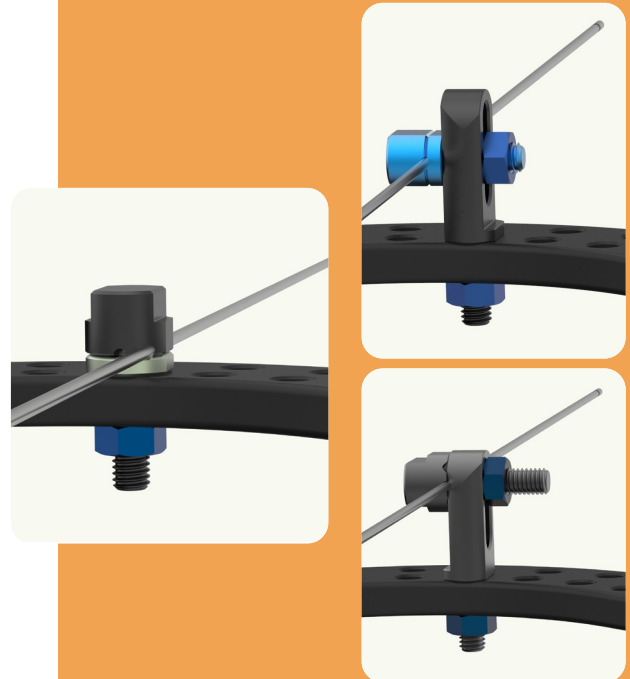

Fig. 6 - Connect Wire to Ring

SURGICAL TECHNIQUE: FOOT FRAME (CONT)

Close Off Foot Ring

- 7 Foot rings must be closed off using a half ring of the same size or alternatively using two cubes and threaded rod.

When using half ring to close off foot ring, attach the half ring to either the vertical hole using 20mm (Green) connection bolt and nut (parallel orientation) (Fig 7a) or to the horizontal threaded hole using just a 20 mm (Green) connection bolt (perpendicular orientation) (Fig 7b).

Warning: Foot Ring must be closed off prior to tensioning of wires

Note: Use GREEN bolts (20mm long) for connecting half ring to foot ring.

Alternate method: When using cubes to close off foot ring, attach it to the vertical non-threaded holes on either ends of the foot ring using 20mm (green) connection bolt. From here, insert pin sleeve through cube holes, then insert threaded rod through the pin sleeves, securing with set screws (Fig 7c).

Note: When choosing threaded rod length, make sure that the rod is long enough to protrude beyond the cubes on either end of the foot ring.

Shown: Foot Ring with Cubes assembled with Threaded Rod and half rings. In certain circumstances, supplemental fixation should be considered. Construct design and weight bearing protocols are to be determined at the surgeon's discretion.

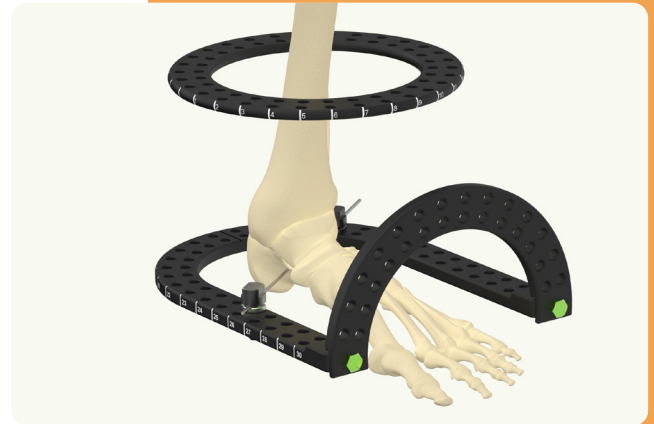

Fig 7a. - Closed off foot ring using half ring in perpendicular orientation

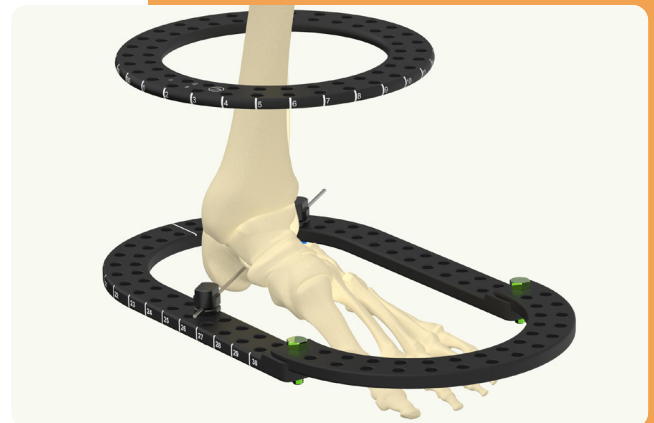

Fig 7b. - Closed off foot ring using half ring in parallel orientation

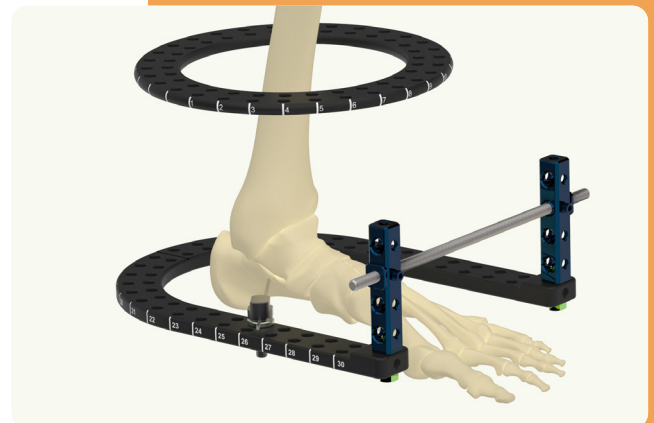

Fig. 7c - Attach Cubes and Close Foot Ring

Tightening Standard Clamps and Connectors

- 8 While using one box end of the 10mm Hex Bolt Wrench to maintain the position of the Clamp, use another 10mm wrench to tighten the nut (Fig. 8). Fully tighten the nut opposite of where the tensioner will be applied.

Caution: Torque Limiting Ratchet Wrench is intended to be used to tighten Shoulder Bolts to Struts. Use with other Connector elements may not provide sufficient torque.

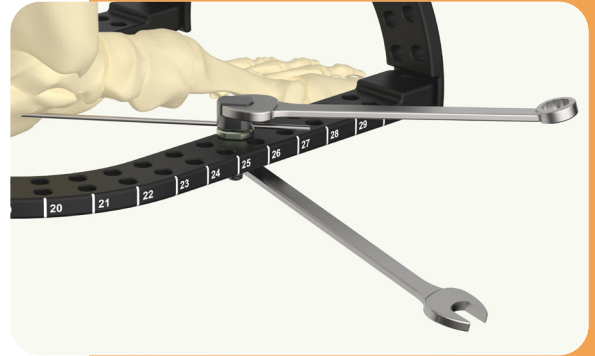

Fig 8 - Fully Tighten Nut

Tensioning

- 9 Position Tensioner over the Wire from the tensioning side of the Ring. Select desired Wire Tensioner Head.

Clamp Compatibility with Tensioner Heads	
Standard Wire Clamp	Fork Tensioner Head Tensioner Head
Side Load Wire Clamp through Thru-Hole	Slotted Tensioner Head Tensioner Head
Side Load Wire Clamp through Side Slot	No Tensioner Head

Ensure Tensioner Head is in contact with the Clamp, Advanced Clamp Post, or Ring before tensioning (Fig. 9). The Wire Tensioner contains markings to indicate amount of tension from 0-125kg. Wires are recommended to be tensioned between 70-125kg.

Caution: If using an Olive Wire, consider the intended use of the Wire within the correction and if a Wire Stopper Washer was used prior to tensioning. Etched lines are present on the Wire to indicate which side of the bone the olive is on.

Warning: Do not use Tensioner Head with Wire Clamp Bolts that do not use washer component.

Caution: The thru-hole and side-load feature of the Side Load Wire Clamp should not be used at the same time.

Note: Take care to keep Wire from bending during tensioning. If needed, Tensioner can be used without a Wire Tensioner Head.

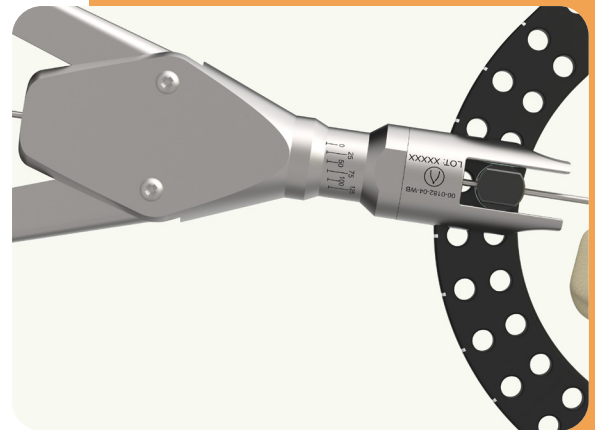

Fig. 9 - Position Tensioner and Tension Wire

SURGICAL TECHNIQUE: **FOOT FRAME** (CONT)

Tighten Wire Bolt and Nut

- 10 Tighten the nut to secure the Wire Clamp on the side of the tensioner to the Ring (Fig. 10).

Caution: Torque Limiting Ratchet Wrench is intended to be used to tighten Shoulder Bolts to Struts. Use with other Connector elements may not provide sufficient torque.



Fig. 10 - Tighten Nut

Wire Trimming

- 11 Using the Wire Cutter/Plier, cut the end of the Wire leaving enough length to allow for additional tensioning on at least one side if needed (Fig. 11).

Wire covers are available for patient comfort.

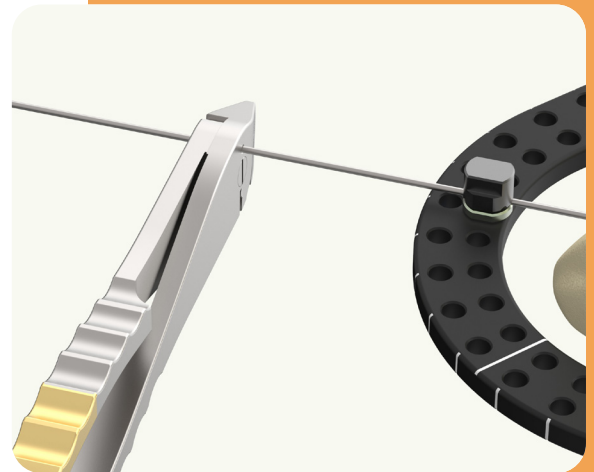

Fig. 11 - Trim Excess Wire

Remaining Half Pin(s) and Wire(s)

- 12 Insert additional Half Pins or Wires, being careful to avoid planned location of Struts.

Caution: Clamps and Cubes may not fit in directly adjacent Ring holes.

Caution: Ensure sufficient fixation internal/external to the frame. It is recommended to insert a minimum of three points of fixation per circular Ring and a minimum of four points of fixation per Foot Ring.

Trim excess length of Wires and/or Half Pins using the Wire Cutter/Plier or Rod Cutter (Fig. 11).

Half Pin and Wire covers are available for patient comfort.

SURGICAL TECHNIQUE: **FOOT FRAME** (CONT)

Select the Appropriate Struts

- 13 Note:** Consider correction goals when selecting Strut size and starting position to avoid frequent Strut exchanges (Fig. 12).



Fig. 12 - Select Strut Type and Size

Fix Struts to Outer Ring

- 14** The Struts must be installed and fixed to the outer Ring a rough triangular geometric configuration. The Struts should be placed in pairs approximately equidistant around the circumference of the Ring and secured to the Ring using Shoulder Bolts (Fig. 13). Tighten Shoulder Bolts using two 10mm wrenches.

Note: It is recommended to tighten the Shoulder Bolts to 8Nm of torque. An 8Nm Torque Limiting Ratchet Wrench is available for Shoulder Bolt tightening.

The modular nature of the Smart Correction System allows surgeons to choose the final position of the Struts, allowing the Struts in a particular pair to be separated by a number of holes for easy access to potential wound sites or skin flaps.

Note: Different diameter Rings can be used in the same frame as needed. Full Rings may also be combined with 2/3 or Foot Rings.

Note: A surgeon must use the recommended six Struts and placed in numbered holes.



Fig. 13 - Secure Struts with Shoulder Bolts

SURGICAL TECHNIQUE: FOOT FRAME (CONT)

Align Strut

- 15 Align the Strut with the intended Ring hole. Position the Strut so that length indicator is visible (Fig. 14).



Fig. 14 - Position Struts Appropriately

Thread Appropriate Bolts

- 16 Thread the appropriate size Shoulder Bolt into the Strut through the outer hole in the Ring (Fig. 15).
 - 6mm Shoulder Bolts (silver) are to be used with Full Rings (6mm thickness) (Fig. 15a).
 - 8mm Shoulder Bolts (purple) are to be used with 1/3, 2/3, 1/2 and Foot Rings (8mm thickness) (Fig. 15b).

Warning: Washers cannot be used at Strut attachment sites.



Fig. 15a - Thread 6mm Shoulder Bolt

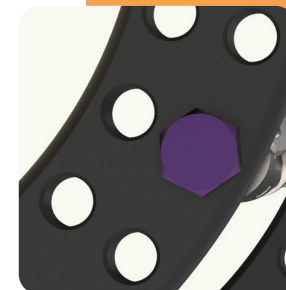

Fig. 15b - Thread 8mm Shoulder Bolt

Adjust Struts to Foot Ring

- 17 Repeat Steps 13-16 for each Strut.

Use Wrenches to Tighten Strut

- 18 Use two 10mm wrenches to tighten the Shoulder Bolts (Fig. 16).

An 8Nm Torque Limiting Ratchet Wrench is available for Shoulder Bolt tightening.



Fig. 16 - Tighten all Shoulder Bolt Connections

Tighten Locking Collar

- 19 If using an Express Strut, tighten Strut Locking Collar counterclockwise until Strut height is fixed in place such that no gross adjustments can be made (Fig. 17).

Note: The Express Strut Locking Collar is designated by straight knurls.

Warning: The use of Standard or Express Struts in a foot frame should only be used in an acute correction situation as the CLick2Correct software is not validated for use with foot frames at this time.

Patients that may attempt unauthorized adjustments and patients with mental, physical, or neurological conditions which may impair the ability to cooperate with the postoperative regimen may not be suitable for use of these devices.



Fig. 17 - Tighten Strut Locking Collar

Re-Tighten Each Bolt and Nut

- 20 All nuts and bolts should be fully tightened with the 10mm Hex Bolt Wrench. The 13mm Hex Bolt Wrench is available for counter-torque on Cubes and Pin Clamps (Fig. 18).

An 8Nm Torque Limiting Ratchet Wrench is available for Shoulder Bolt tightening.

Caution: The Torque Limiting Ratchet Wrench is intended to be used to tighten Shoulder Bolts to Struts. Use with other Connector elements may not provide sufficient torque.

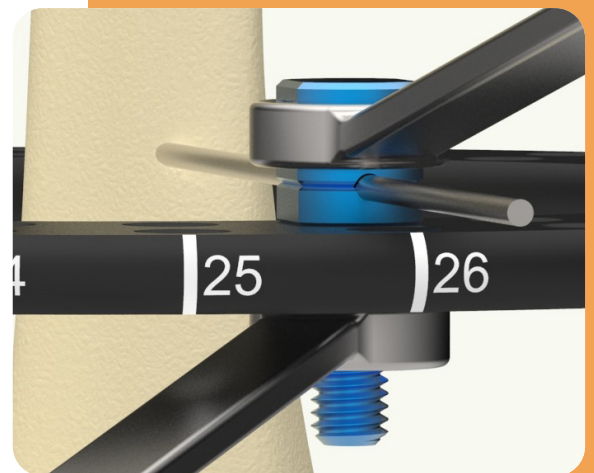

Fig. 18 - Tighten All Connections

Consider Mounting a 2nd Level of Fixation to Increase Stability

- 21 A Full Ring can be built above a previously affixed Ring using a 2/3 and 1/3 Ring of the same size, 105mm or larger, with the 1/3-2/3 Ring Connector, 20mm (green) Connection Bolts (x2) and nuts (x2) (Fig. 19a) or two 1/2 Rings of the same size with 20mm (green) Connection Bolts (x2) and Nuts (x2) (Fig. 19b).

Note: Use GREEN bolts (20mm long) for connecting any two partial rings (2/3, 1/2, 1/3).

Partial Rings (2/3, 1/2, 1/3) may be attached to the frame using Struts or Threaded Rods in approximate equidistant position (Fig. 20).

Warning: Single hole at the two ends of each half ring is to be used only for connecting to another half ring and not for other frame elements.

Nuts are available to be placed on either side of the Ring-Threaded Rod attachment site.

Dual Rod Connectors (Optional)

If the desired Threaded Rod length is unavailable, Dual Rod Connectors may be used to connect two Threaded Rods together to create an overall length up to 300mm.

The Threaded Rods should be fully threaded into the Connector such that the ends of the Threaded Rods are touching at the approximate center of the Dual Rod Connector. Nuts are available to be placed on either side of the Dual Rod Connector to assist with locking in place the position of the Dual Rod Connector.

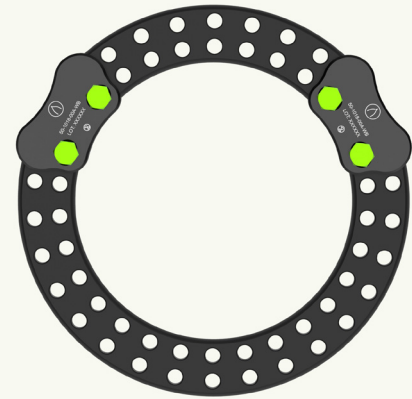

Fig. 19a - Assemble 2nd Level of Frame (if Needed)

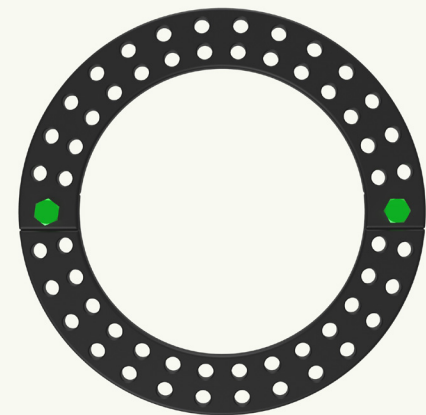

Fig. 19b - Assemble 2nd Level of Frame (if Needed)

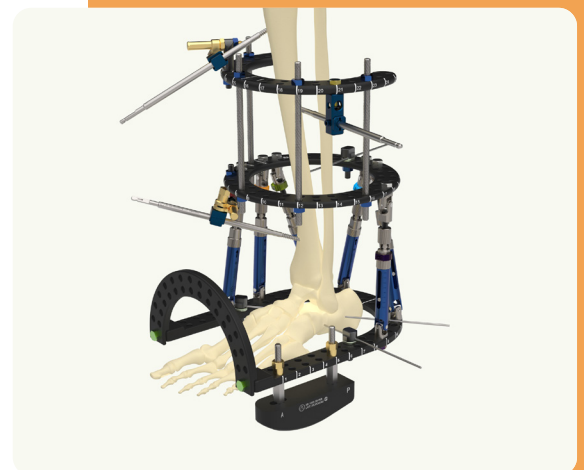

Fig. 20 - Assemble 2nd Level of Frame with Threaded Rods

SURGICAL TECHNIQUE: FOOT FRAME (CONT)

Walking Foot Attachment

22 The Walking Foot Attachment is available for attachment to the Foot Ring as necessary. The Walking Foot Attachment should have 3 Ring holes between the attachment sites (Fig. 21). Consider Walking Foot Attachment placement prior to final tightening of Clamps, Struts, and Threaded Rods on the Foot Ring.

Note: Number of available holes may be limited on the 70mm, 80mm and 90 mm foot rings for attaching Walking foot attachment. Although it is preferable to attach the walking foot attachment on the straight section of the foot ring, the holes on the curved section may be used if necessary.

Threaded Rods should be used through the Ring holes and Walking Foot Attachment holes. Standard Nuts should be used on the bottom side of the Walking Foot Attachment and assembled first (Fig. 22).

Dual Rod Connectors (20mm, 40mm, 60mm) are available to add between the Ring and Walking Foot Attachment as necessary to lift the foot off of the ground up to 60mm and/or to connect the Walking Foot Attachment.

Standard or Long Nuts should be used at final assembly to attach the Threaded Rod to the Ring from above (Fig. 22).

Caution: Weight bearing activities should be permitted at surgeon's discretion.

Patient Safety & Comfort

23 Pin and Wire covers are available to place at the end of cut Half Pin and Wires.

Silverlon Lifesaver® Ag pin site dressing, Sponges, and Sponge Clips are available for use at anchorage insertion sites to aid with pin site maintenance (Fig. 23). Silverlon Lifesaver® Ag pin site dressing and/or Sponges can be placed on the insertion site with Sponge Clips available to attach to the anchorage element to hold the Sponge in place. Silverlon Lifesaver® Ag pin site dressings are available in 1.5mm diameter for use with wires and a 4.0mm diameter for use with Half Pins. Activate the Silverlon Lifesaver® Ag pin site dressings by wetting them with sterile water, distilled water, or normal saline. Place the silver side of the dressing in direct contact with the skin.



SMART

Correction™
EXTERNAL FIXATOR SYSTEM

System Components & Case Layouts

COMPONENTS (CONT)

FULL RINGS

Dual Hole Full Ring, 70mm ID, Aluminum
Dual Hole Full Ring, 80mm ID, Aluminum
Dual Hole Full Ring, 90mm ID, Aluminum
Dual Hole Full Ring, 105mm ID, Aluminum
Dual Hole Full Ring, 120mm ID, Aluminum
Dual Hole Full Ring, 135mm ID, Aluminum
Dual Hole Full Ring, 150mm ID, Aluminum
Dual Hole Full Ring, 165mm ID, Aluminum
Dual Hole Full Ring, 180mm ID, Aluminum
Dual Hole Full Ring, 195mm ID, Aluminum
Dual Hole Full Ring, 210mm ID, Aluminum
Dual Hole Full Ring, 225mm ID, Aluminum
Dual Hole Full Ring, 240mm ID, Aluminum

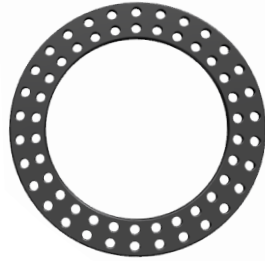

2/3 RINGS

Dual Hole 2/3 Ring, 70mm ID, Aluminum
Dual Hole 2/3 Ring, 80mm ID, Aluminum
Dual Hole 2/3 Ring, 90mm ID, Aluminum
Dual Hole 2/3 Ring, 105mm ID, Aluminum
Dual Hole 2/3 Ring, 120mm ID, Aluminum
Dual Hole 2/3 Ring, 135mm ID, Aluminum
Dual Hole 2/3 Ring, 150mm ID, Aluminum
Dual Hole 2/3 Ring, 165mm ID, Aluminum
Dual Hole 2/3 Ring, 180mm ID, Aluminum
Dual Hole 2/3 Ring, 195mm ID, Aluminum
Dual Hole 2/3 Ring, 210mm ID, Aluminum
Dual Hole 2/3 Ring, 225mm ID, Aluminum
Dual Hole 2/3 Ring, 240mm ID, Aluminum



1/3 RINGS

Dual Hole 1/3 Ring, 105mm ID, Aluminum
Dual Hole 1/3 Ring, 120mm ID, Aluminum
Dual Hole 1/3 Ring, 135mm ID, Aluminum
Dual Hole 1/3 Ring, 150mm ID, Aluminum
Dual Hole 1/3 Ring, 165mm ID, Aluminum
Dual Hole 1/3 Ring, 180mm ID, Aluminum
Dual Hole 1/3 Ring, 195mm ID, Aluminum
Dual Hole 1/3 Ring, 210mm ID, Aluminum
Dual Hole 1/3 Ring, 225mm ID, Aluminum
Dual Hole 1/3 Ring, 240mm ID, Aluminum



1/2 RINGS

Dual Hole Half Ring, 70mm ID, Aluminum
Dual Hole Half Ring, 80mm ID, Aluminum
Dual Hole Half Ring, 90mm ID, Aluminum
Dual Hole Half Ring, 120mm ID, Aluminum
Dual Hole Half Ring, 150mm ID, Aluminum
Dual Hole Half Ring, 180mm ID, Aluminum
Dual Hole Half Ring, 210mm ID, Aluminum



FOOT RINGS

Dual Hole Foot Ring, 70mm ID, Short, Aluminum
Dual Hole Foot Ring, 70mm ID, Aluminum
Dual Hole Foot Ring, 80mm ID, Short, Aluminum
Dual Hole Foot Ring, 80mm ID, Aluminum
Dual Hole Foot Ring, 90mm ID, Short, Aluminum
Dual Hole Foot Ring, 90mm ID, Aluminum
Dual Hole Foot Ring, 120mm ID, Short, Aluminum
Dual Hole Foot Ring, 120mm ID, Aluminum
Dual Hole Foot Ring, 150mm ID, Short, Aluminum
Dual Hole Foot Ring, 150mm ID, Aluminum
Dual Hole Foot Ring, 180mm ID, Short, Aluminum
Dual Hole Foot Ring, 180mm ID, Aluminum
Dual Hole Foot Ring, 210mm ID, Short, Aluminum
Dual Hole Foot Ring, 210mm ID, Aluminum

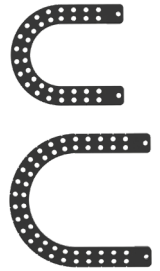

DUAL JOINT STRUTS

Dual Joint Express Strut, XShort
Dual Joint Express Strut, Short
Dual Joint Express Strut, Medium
Dual Joint Express Strut, Long
Dual Joint Exp. Strut, XXShort
Dual Joint Standard Strut, XXShort
Dual Joint Standard Strut, XShort
Dual Joint Standard Strut, Short
Dual Joint Standard Strut, Medium
Dual Joint Standard Strut, Long



All components are offered non-sterile unless otherwise specified.

Highlighted items are contained within sterilization cases (see case & tray layouts).

COMPONENTS (CONT)

CLAMPS	Side Load Wire Clamp	
	Standard Wire Clamp	
	Advanced Pin Clamp	
	Standard Pin Clamp	
	Advanced Clamp Post, Small, 26mm	
	Advanced Clamp Post, Large, 42mm	

THREADED RODS	Threaded Rod, 60mm length, SS	
	Threaded Rod, 80mm length, SS	
	Threaded Rod, 100mm length, SS	
	Threaded Rod, 120mm length, SS	
	Threaded Rod, 150mm length, SS	
	Threaded Rod, 200mm length, SS	
	Threaded Rod, 250mm length, SS	
	Threaded Rod, 300mm length, SS	

DUAL ROD CONNECTORS	Dual Rod Connector, Short
	Dual Rod Connector, Medium
	Dual Rod Connector, Long

BOLTS	Connection Bolt, Short, 12mm (2 pack)
	Connection Bolt, Short, 12mm
	Connection Bolt, Medium, 16mm
	Connection Bolt, Long, 20mm
	Shoulder Bolt, 6mm - Sterile
	Shoulder Bolt, 6mm
	Shoulder Bolt, 6mm (6 pack)
	Shoulder Bolt, 8mm - Sterile
	Shoulder Bolt, 8mm
	Shoulder Bolt, 8mm (6 pack)

WASHERS	Washer
	Washer (10 pack)
	Locking Washer
	Wire Stopper Washer, SS
	Wire Stopper Washer, SS - Sterile
	Locking Washer - Sterile

CUBES	Cube, 1 Hole
	Cube, 2 Hole
	Cube, 3 Hole
	Cube, 4 Hole
	Cube, 5 Hole
	Pin Sleeve and Set Screw - Sterile
Pin Sleeve for Cube, 6mm	
Set Screw, 6mm	



WIRES	Wire - 1.6mm, Bayonet Tip, SS
	Wire - 2.0mm, Bayonet Tip, SS
	Olive Wire - 1.6mm, Bayonet Tip, SS
	Olive Wire - 2.0mm, Bayonet Tip, SS

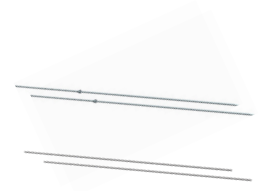

NUTS	Standard Nut - Sterile
	Standard Nut
	Standard Nut (10 pack)
	Long Nut
	Long Nut, 12.8mm - Sterile

ACCESSORIES	Wire Cover 1.6 - Sterile
	Wire Cover 1.6
	Wire Cover 1.6 (6 pack)
	Wire Cover 2.0 - Sterile
	Wire Cover 2.0
	Wire Cover 2.0 (6 pack)



Half Pin Covers, 6mm - Sterile
Half Pin Covers, 6mm
Half Pin Covers, 6mm (6 pack)

Strut ID Clips

Strut ID Kit - Sterile
Walking Foot Attachment
Sponge Clips (12 pack)



Sponges (30 pack) - Sterile
Silverlon Lifesaver® Ag 1" Diameter with 1.5mm - Sterile
Silverlon Lifesaver® Ag 1" Diameter with 4.0mm - Sterile



All components are offered non-sterile unless otherwise specified.

Highlighted items are contained within sterilization cases (see case & tray layouts).

COMPONENTS (CONT)

INSTRUMENTS

13mm Hex Bolt Wrench
10mm Hex Bolt Ratchet Wrench
10mm Socket Wrench
Slotted Wrench
10mm Hex Bolt Wrench
T-Allen Wrench, 3mm/150mm
8Nm Torque Limiting Ratchet Wrench
10mm Hex Bolt Socket
T-Handle for Half Pins (AO Connector)
T-Handle w/ Jacobs Chuck
Depth Gauge, 60mm



Wire Cutter/Plier
Drill Sleeve Handle
Drill Sleeve Guide - Long
Drill Sleeve Guide - Short
Trocar - Long
Trocar - Short
Single Hand Wire Tensioner
Fork Tensioner Head
Tensioner Head
Slotted Tensioner Head

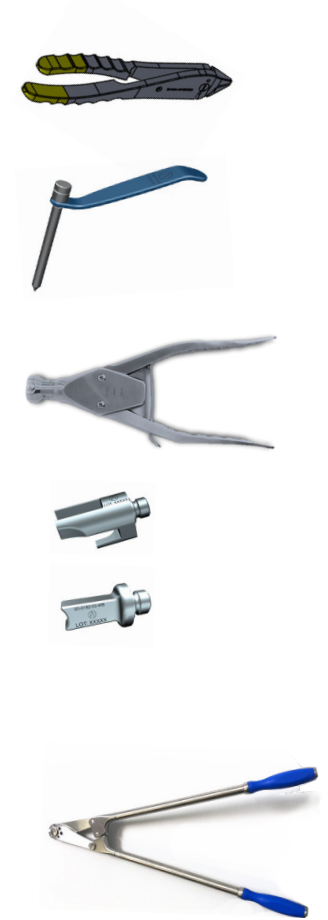

Rod Cutter

6mm AO Quick Release Adaptor - Sterile*

DRILL BITS

AO Drill Bit 3.2 x 200mm
AO Drill Bit 4.8 x 200mm
AO Drill Bit 3.2 x 200mm, Sterile
AO Drill Bit 4.8 x 200mm, Sterile
4.0mm Drill Bit for HA Half Pins Long - Sterile*
4.0mm Drill Bit for HA Half Pins Short - Sterile*



All components are offered non-sterile unless otherwise specified.
*For use with sterile HA Half Pins.

Highlighted items are contained within sterilization cases (see case & tray layouts).

COMPONENTS (CONT)

Half Pins (Self-Drilling)



4.5MM HALF PINS

Half Pin, 4.5/120/20mm, Self-Drilling, QC, SS - NS
Half Pin, 4.5/120/30mm, Self-Drilling, QC, SS - NS
Half Pin, 4.5/120/40mm, Self-Drilling, QC, SS - NS
Half Pin, 4.5/150/20mm, Self-Drilling, QC, SS - NS
Half Pin, 4.5/150/30mm, Self-Drilling, QC, SS - NS
Half Pin, 4.5/150/40mm, Self-Drilling, QC, SS - NS
Half Pin, 4.5/150/50mm, Self-Drilling, QC, SS - NS

5.0MM HALF PINS

Half Pin, 5.0/120/30mm, Self-Drilling, QC, SS - NS
Half Pin, 5.0/120/40mm, Self-Drilling, QC, SS - NS
Half Pin, 5.0/150/30mm, Self-Drilling, QC, SS - NS
Half Pin, 5.0/150/40mm, Self-Drilling, QC, SS - NS
Half Pin, 5.0/150/50mm, Self-Drilling, QC, SS - NS
Half Pin, 5.0/180/30mm, Self-Drilling, QC, SS - NS
Half Pin, 5.0/180/40mm, Self-Drilling, QC, SS - NS
Half Pin, 5.0/180/50mm, Self-Drilling, QC, SS - NS
Half Pin, 5.0/200/30mm, Self-Drilling, QC, SS - NS
Half Pin, 5.0/200/40mm, Self-Drilling, QC, SS - NS
Half Pin, 5.0/200/50mm, Self-Drilling, QC, SS - NS
Half Pin, 5.0/220/30mm, Self-Drilling, QC, SS - NS
Half Pin, 5.0/220/40mm, Self-Drilling, QC, SS - NS
Half Pin, 5.0/220/50mm, Self-Drilling, QC, SS - NS
Half Pin, 5.0/250/30mm, Self-Drilling, QC, SS - NS
Half Pin, 5.0/250/40mm, Self-Drilling, QC, SS - NS
Half Pin, 5.0/250/50mm, Self-Drilling, QC, SS - NS

6.0MM HALF PINS

Half Pin, 6.0/150/30mm, Self-Drilling, QC, SS - NS
Half Pin, 6.0/150/40mm, Self-Drilling, QC, SS - NS
Half Pin, 6.0/180/30mm, Self-Drilling, QC, SS - NS
Half Pin, 6.0/180/40mm, Self-Drilling, QC, SS - NS
Half Pin, 6.0/200/30mm, Self-Drilling, QC, SS - NS
Half Pin, 6.0/200/40mm, Self-Drilling, QC, SS - NS
Half Pin, 6.0/200/50mm, Self-Drilling, QC, SS - NS
Half Pin, 6.0/220/30mm, Self-Drilling, QC, SS - NS
Half Pin, 6.0/220/40mm, Self-Drilling, QC, SS - NS
Half Pin, 6.0/220/50mm, Self-Drilling, QC, SS - NS
Half Pin, 6.0/250/30mm, Self-Drilling, QC, SS - NS
Half Pin, 6.0/250/40mm, Self-Drilling, QC, SS - NS
Half Pin, 6.0/250/50mm, Self-Drilling, QC, SS - NS

Half Pins (Blunt Self-Tapping)



4.5MM HALF PINS

Half Pin, 4.5/120/20mm, Blunt Self Tapping, QC, SS - NS
Half Pin, 4.5/120/30mm, Blunt Self Tapping, QC, SS - NS
Half Pin, 4.5/120/40mm, Blunt Self Tapping, QC, SS - NS
Half Pin, 4.5/150/30mm, Blunt Self Tapping, QC, SS - NS
Half Pin, 4.5/150/40mm, Blunt Self Tapping, QC, SS - NS

5.0MM HALF PINS

Half Pin, 5.0/120/30mm, Blunt Self Tapping, QC, SS - NS
Half Pin, 5.0/120/40mm, Blunt Self Tapping, QC, SS - NS
Half Pin, 5.0/150/30mm, Blunt Self Tapping, QC, SS - NS
Half Pin, 5.0/150/40mm, Blunt Self Tapping, QC, SS - NS
Half Pin, 5.0/150/50mm, Blunt Self Tapping, QC, SS - NS
Half Pin, 5.0/180/30mm, Blunt Self Tapping, QC, SS - NS
Half Pin, 5.0/180/40mm, Blunt Self Tapping, QC, SS - NS
Half Pin, 5.0/180/50mm, Blunt Self Tapping, QC, SS - NS
Half Pin, 5.0/200/30mm, Blunt Self Tapping, QC, SS - NS
Half Pin, 5.0/200/40mm, Blunt Self Tapping, QC, SS - NS
Half Pin, 5.0/200/50mm, Blunt Self Tapping, QC, SS - NS
Half Pin, 5.0/220/30mm, Blunt Self Tapping, QC, SS - NS
Half Pin, 5.0/220/40mm, Blunt Self Tapping, QC, SS - NS
Half Pin, 5.0/220/50mm, Blunt Self Tapping, QC, SS - NS
Half Pin, 5.0/250/30mm, Blunt Self Tapping, QC, SS - NS
Half Pin, 5.0/250/40mm, Blunt Self Tapping, QC, SS - NS
Half Pin, 5.0/250/50mm, Blunt Self Tapping, QC, SS - NS

6.0MM HALF PINS

Half Pin, 6.0/150/30mm, Blunt Self Tapping, QC, SS - NS
Half Pin, 6.0/150/40mm, Blunt Self Tapping, QC, SS - NS
Half Pin, 6.0/180/30mm, Blunt Self Tapping, QC, SS - NS
Half Pin, 6.0/180/40mm, Blunt Self Tapping, QC, SS - NS
Half Pin, 6.0/200/30mm, Blunt Self Tapping, QC, SS - NS
Half Pin, 6.0/200/40mm, Blunt Self Tapping, QC, SS - NS
Half Pin, 6.0/200/50mm, Blunt Self Tapping, QC, SS - NS
Half Pin, 6.0/220/30mm, Blunt Self Tapping, QC, SS - NS
Half Pin, 6.0/220/40mm, Blunt Self Tapping, QC, SS - NS
Half Pin, 6.0/250/30mm, Blunt Self Tapping, QC, SS - NS
Half Pin, 6.0/250/40mm, Blunt Self Tapping, QC, SS - NS

All components are offered non-sterile unless otherwise specified.

Highlighted items are contained within sterilization cases (see case & tray layouts).

COMPONENTS (CONT)

Half Pins (Self-Drilling) - Sterile



6.0MM HALF PINS

HA Half Pin, 6mm, 120x30, Self-Drilling
HA Half Pin, 6mm, 150x44, Self-Drilling
HA Half Pin, 6mm, 150x40, Self-Drilling
HA Half Pin, 6mm, 180x50, Self-Drilling

Half Pins (Pre-Drilling Needed) - Sterile



6.0MM HALF PINS

HA Half Pins, 6mm, 150x40
HA Half Pins, 6mm, 150x50

Half Pins (Self-Drilling) HA Extended Onto Shaft - Sterile



6.0MM HALF PINS

HA Half Pin, 6mm, 150x30, Self-Drilling, Extended Coating
HA Half Pin, 6mm, 180x35, Self-Drilling, Extended Coating
HA Half Pin, 6mm, 200x40, Self-Drilling, Extended Coating

All components are offered non-sterile unless otherwise specified.

CASE LAYOUTS

SC-RINGCASE1 Smart Correction **Full Ring Case**

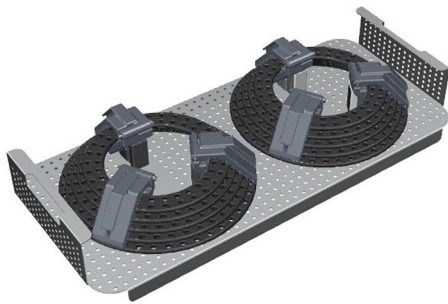

Full Aluminum Rings

ITEM #	DESCRIPTION	QTY
50-1012-10A-WB	Dual Hole Full Ring, 105mm ID, Aluminum	2
50-1012-12A-WB	Dual Hole Full Ring, 120mm ID, Aluminum	2
50-1012-13A-WB	Dual Hole Full Ring, 135mm ID, Aluminum	2
50-1012-15A-WB	Dual Hole Full Ring, 150mm ID, Aluminum	2
50-1012-16A-WB	Dual Hole Full Ring, 165mm ID, Aluminum	2
50-1012-18A-WB	Dual Hole Full Ring, 180mm ID, Aluminum	2

SC-RINGCASE2 Smart Correction **Two-Third and Foot Ring Case**

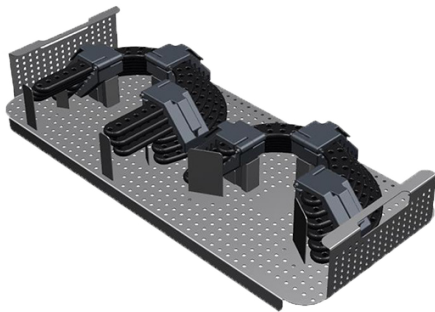

2/3 Aluminum Rings

50-1017-10A-WB	Dual Hole 2/3 Ring, 105mm ID, Aluminum	1
50-1017-12A-WB	Dual Hole 2/3 Ring, 120mm ID, Aluminum	1
50-1017-13A-WB	Dual Hole 2/3 Ring, 135mm ID, Aluminum	1
50-1017-15A-WB	Dual Hole 2/3 Ring, 150mm ID, Aluminum	2
50-1017-16A-WB	Dual Hole 2/3 Ring, 165mm ID, Aluminum	2
50-1017-18A-WB	Dual Hole 2/3 Ring, 180mm ID, Aluminum	2

SC-CLAMPCASE Smart Correction **Clamps and Bolts Case**

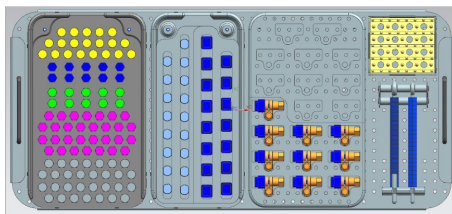

50-1041-00-WB	Standard Wire Clamp	17
50-1042-30-WB	Advanced Pin Clamp	10
50-1042-00-WB	Standard Pin Clamp	15
50-1052-01-WB	Standard Nut	60
50-1053-12-WB	Connection Bolt, Short, 12mm	20
50-1053-16-WB	Connection Bolt, Medium, 16mm	10
50-1053-20-WB	Connection Bolt, Long, 20mm	10
50-1153-06-WB	Shoulder Bolt, 6mm	30
50-1153-08-WB	Shoulder Bolt, 8mm	30
50-1051-00-WB	Washer	60

CASE LAYOUTS (CONT)

SC-STRUTCASE Smart Correction **Strut Case**

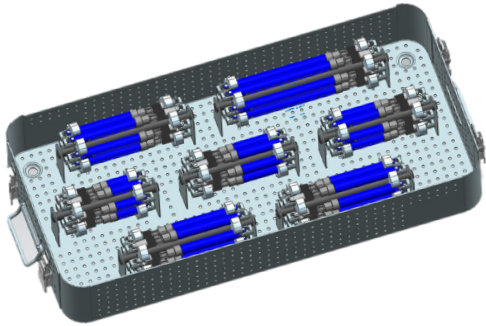

Dual Joint Struts

ITEM #	DESCRIPTION	QTY
50-1032-01-WB	Dual Joint Exp. Strut, XShort	6
50-1032-02-WB	Dual Joint Exp. Strut, Short	12
50-1032-03-WB	Dual Joint Exp. Strut, Medium	18
50-1032-04-WB	Dual Joint Exp. Strut, Long	6

SC-PINCASE Smart Correction **Pins and Wires Case**

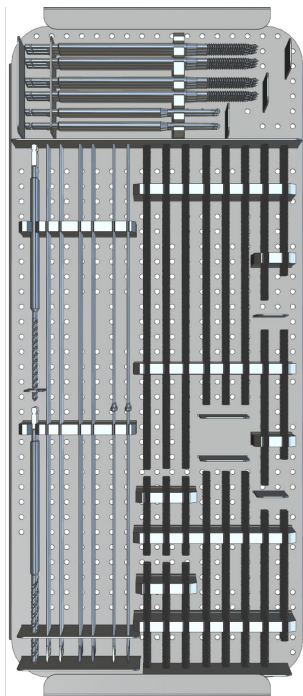

Threaded Rods

50-1057-60S-WB	Threaded Rod, 60mm length, SS	6
50-1057-80S-WB	Threaded Rod, 80mm length, SS	6
50-1057-100S-WB	Threaded Rod, 100mm length, SS	6
50-1057-120S-WB	Threaded Rod, 120mm length, SS	6
50-1057-150S-WB	Threaded Rod, 150mm length, SS	6
50-1057-200S-WB	Threaded Rod, 200mm length, SS	6
50-1057-250S-WB	Threaded Rod, 250mm length, SS	6

Drill Bits

00-6200-32-WB	AO Drill Bit 3.2 x 200mm	2
00-6200-48-WB	AO Drill Bit 4.8 x 200mm	2

Wires

50-1071-16S-WB	Wire - 1.6mm, Bayonet Tip, SS	10
50-1071-20S-WB	Wire - 2.0mm, Bayonet Tip, SS	10
50-1072-16S-WB	Olive Wire - 1.6mm, Bayonet Tip, SS	4
50-1072-20S-WB	Olive Wire - 2.0mm, Bayonet Tip, SS	4

Half Pins

50-1850-204S-WB	Half Pin, 5.0/200/40mm, Self-Drilling, QC, SS	6
50-1850-184S-WB	Half Pin, 5.0/180/40mm, Self-Drilling, QC, SS	6
50-1845-154S-WB	Half Pin, 4.5/150/40mm, Self-Drilling, QC, SS	4

CASE LAYOUTS (CONT)

SC-INSTCASE1

Smart Correction Instrument Case 1

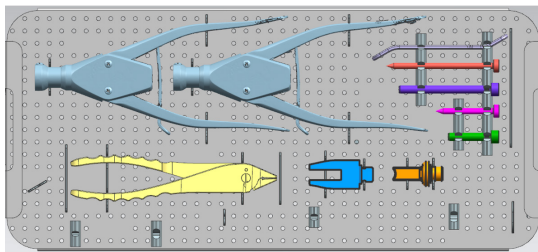

ITEM #	DESCRIPTION	QTY
00-6200-48-WB	Wire Cutter/Plier	1
00-0046-50-WB	Drill Sleeve Handle	1
00-0046-51-WB	Drill Sleeve Guide - Long	1
00-0046-52-WB	Drill Sleeve Guide - Short	1
00-0046-52-WB	Trocar - Long	1
00-0046-52-WB	Trocar - Short	1
00-0182-01-WB	Single Hand Wire Tensioner	2
00-0182-02-WB	Fork Tensioner Head	1
00-0182-03-WB	Tensioner Head	1

SC-INSTCASE2

Smart Correction Instrument Case 2

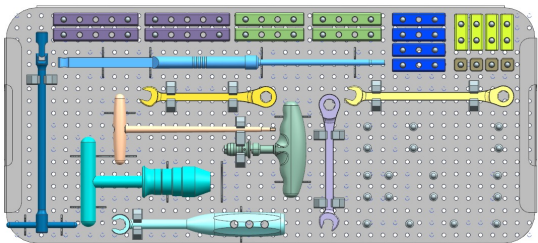

00-2055-13-WB	13mm Hex Bolt Wrench	1
00-2055-10R-WB	10mm Hex Bolt Ratchet Wrench	1
00-2055-10S-WB	10mm Socket Wrench	1
00-2054-10-WB	Slotted Wrench	1
00-2055-10-WB	10mm Hex Bolt Wrench	2
00-2033-15T-WB	T-Allen Wrench, 3mm/150mm	1
00-1043-AO-WB	T-Handle for Half Pins (AO Connector)	1
00-1043-JC-WB	T-Handle w/ Jacobs Chuck	1
00-0014-60-WB	Depth Gauge, 60mm	1
50-1056-01-WB	Cube, 1 Hole	4
50-1056-02-WB	Cube, 2 Hole	4
50-1056-03-WB	Cube, 3 Hole	4
50-1056-04-WB	Cube, 4 Hole	4
50-1056-05-WB	Cube, 5 Hole	4



WishBoneMedical.com

100 Capital Drive
Warsaw, IN 46582
+1-574-306-4006

All trademarks here in are the property of WishBone Medical, Inc. or its subsidiaries unless otherwise indicated. This material is intended for the sole use and benefit of Health Care Professionals and the WishBone Medical Sales Force. It is not to be redistributed, duplicated or disclosed without the express written consent of WishBone Medical.

Caution: Federal law restricts this device to sale by or on the order of a physician.

The MR environment presents risks to patients with metal implants. Physicians should consider the risks when recommending MR imaging for patients with metal implants.

The Smart Correction System components have not been evaluated for safety in the MR environment. They have not been tested for heating or unwanted movement in the MR environment. The safety of the Smart Correction System in the MR environment is unknown. Performing an MR exam on a person who has this medical device may result in injury or device malfunction.

For product information, including indications, contraindications, warnings, precautions and potential adverse effects, visit WishBone Medical's Instructions for Use page online: www.WishBoneMedical.com/IFU.